

# PMX condensing unit





	Page
Introduction, scope, disclaimer	4
Safety information	5
Unit models	7
Features & benefits	7
CDU layout	8
Scope of supply	9
Electrical connections	9
CDU performance/technical data	11
Installation & start-up	23
Commissioning report	28
About Copeland	32

## ***Introduction***

Copeland PMX condensing unit comes with Copeland scroll compressors with liquid injection technology.

This document is designed to help the contractor and customer for the installation, commissioning & operation of Copeland's PMX condensing unit.

Scope of supply - Check page number 9 of this manual for detailed scope of supply.

## ***Disclaimer***

Thank you for purchasing the Copeland PMX condensing unit. We hope that this product meets your intended refrigeration requirement. Please read through this operation manual to familiarize yourself with the installation, commissioning and operation of this product. Please do read the following information in this page before proceeding with the rest of the manual.

The Copeland PMX scroll refrigeration condensing units should only be installed by suitably qualified and experienced refrigeration technicians. No responsibility can be accepted for damage caused by inexperienced or inadequately trained site technicians or improper system design. All instructions and procedures described in this manual are based on good refrigeration trade practices as applicable to this particular product. The installation contractor may prefer to use variations to these recommendations. However, the methods described in this manual represent the minimum requirements to avoid any subsequent warranty claims for this equipment and its components. These instructions do not cover the fundamentals of good electrical or refrigeration practice and are therefore intended for use only by qualified and/or experienced personnel or technicians.

For any additional query, please consult your local sales office, quoting unit model and serial number as shown on the nameplate. In case of ambiguity, the wiring diagram supplied with each unit takes precedence over the diagram in this manual.

# 1. Safety information







## 1.1

Installation and commissioning work on compressor pack shall be carried out only by qualified, accredited refrigeration personnel who have been trained and instructed.

## 1.2

PMX condensing unit is manufactured according to the latest safety standards. Emphasis has been placed on the user's safety. For relevant standards please refer to the manufacturer's declaration, available on request. These instructions should be retained throughout the lifetime of the compressor pack. You are strongly advised to follow these safety instructions.

## 1.3 Icon explanation

 <b>WARNING</b> This icon indicates instructions to avoid personal injury and material damage.	 <b>CAUTION</b> This icon indicates instructions to avoid property damage and possible personal injury.
 <b>HIGH VOLTAGE</b> This icon indicates operations with a danger of electric shock.	 <b>IMPORTANT</b> This icon indicates instructions to avoid malfunction of the compressor.
 <b>DANGER OF BURNING OR FROSTBITE</b> This icon indicates operations with a danger of burning or frostbite.	<b>NOTE</b> This word indicates a recommendation for easier operation.
 <b>EXPLOSION HAZARD</b> This icon indicates instructions operations with a danger of explosion.	

## 1.4 Safety statements

- Only qualified and authorized refrigeration personnel are permitted to install, commission and maintain this equipment.
- Electrical connections must be made by qualified electrical personnel.
- All valid standards for connecting electrical and refrigeration equipment must be observed.
- The national legislation and regulations regarding personnel protection must be observed.



Use personal safety equipment. Safety goggles, gloves, protective clothing, safety boots and hard hats should be worn where necessary.

## 1.5 General instructions

### Warning



**System breakdown! Personal injuries!** Never install a system in the field and leave it unattended when it has no charge, a holding charge, or with the service valves closed without electrically locking out the system.

**System breakdown! Personal injuries!** Only approved refrigerants and refrigeration oils must be used.

### Warning



**High shell temperature! Burning!** Do not touch the compressor until it has cooled down. Ensure that other materials in the area of the compressor do not get in touch with it. Lock and mark accessible sections.

### Caution



**Overheating! Bearing damage!** Do not operate compressors without refrigerant charge or without being connected to the system.

### Caution



Compressors contain oil & refrigerant under pressure. Release pressure from both high & low side of compressor before servicing.

### Caution



Tube brazing & compressor operation can produce hot surfaces. To avoid burns, allow surfaces to cool.

## 1.6 Safety refrigerants/lubricant

- a. Please use correct refrigerant as designed to work in safe operating envelope.
- b. Compressor is supplied with an initial oil charge. The standard oil charge for use with HFC refrigerant is polyolester (POE) lubricant Emkarate RL 32 3MAF.

## 2. Models

CDU model	Compressor model	Power supply
PMX1A-ZB21-TF5-1	ZB21KQE-TF5	220-240 V / 3~ / 60 Hz
PMX1A-ZB21-TF7-1	ZB21KQE-TF7	380-420 V / 3~ / 60 Hz
PMX2A-ZB45-TF5-1	ZB45KQE-TF5	220-240 V / 3~ / 60 Hz
PMX2A-ZB45-TF7-1	ZB45KQE-TF7	380-420 V / 3~ / 60 Hz
PMX1A-ZB26-TFM-1	ZB26KQE-TFD	380-420 V / 3~ / 50 Hz
PMX2A-ZB38-TFM-1	ZB38KQE-TFD	380-420 V / 3~ / 50 Hz
PMX2A-ZB48-TFM-1	ZB48KQE-TFD	380-420 V / 3~ / 50 Hz

## 3. Features and benefits

Features	Benefits
Scroll compressor	<ul style="list-style-type: none"> <li>• High efficiency</li> <li>• Compliance mechanism for resistance to liquid flood back</li> <li>• Scroll geometry optimized at low condensing temp where runs most of the year</li> <li>• Sound shell allows reduction of 10...12dBA</li> <li>• Smaller motors and light weight</li> <li>• Easier to change/retrofit</li> <li>• Large operating envelope</li> </ul>
Condenser	<ul style="list-style-type: none"> <li>• Optimized condenser coil for maximum heat transfer</li> </ul>
Accessories	<ul style="list-style-type: none"> <li>• Alco PS1 LP Cut-out for safety</li> <li>• Hermetic moisture indicator</li> <li>• Filter drier</li> </ul>

#### 4. Physical layout of the unit:

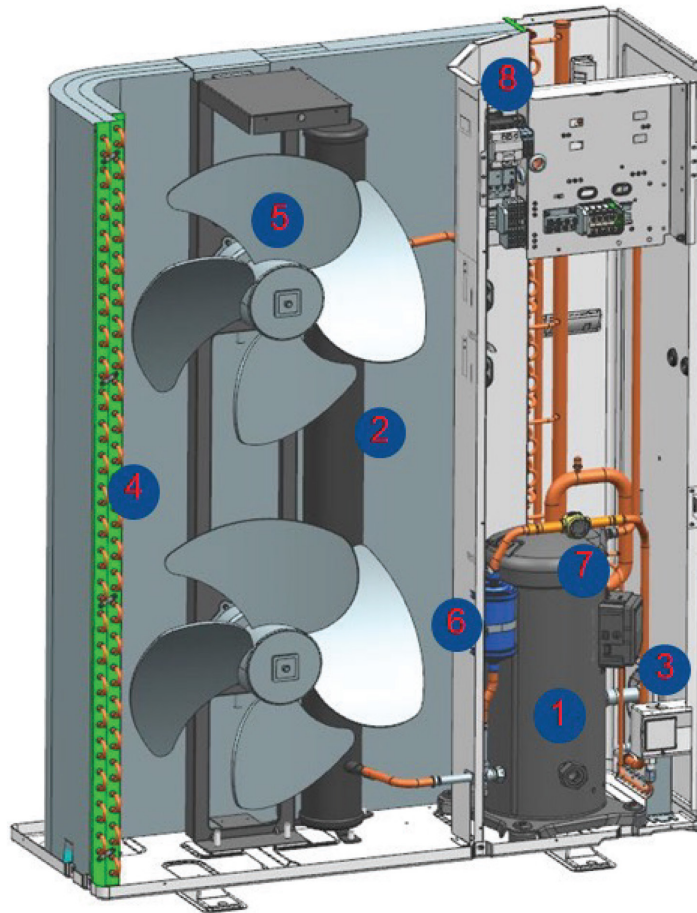

Item	Description
1	Scroll compressor
2	Liquid receiver
3	LP cut-out
4	Condenser
5	Fan
6	Filter drier
7	Hermetic moisture indicator
8	Power contactor



## 5. Scope of supply

CDU model	PMX1A-ZB21-TF5/TF7 PMX1A-ZB26-TFM-1	PMX2A-ZB45-TF5/TF7	PMX2A-ZB38/48-TFM-1
Liquid line filter dryer	✓	✓	✓
Sight glass	✓	✓	✓
Adjustable LP switch	✓	✓	✓
Thermal overload relay	✓	✓	✓
Power contactor	✓	✓	✓

## 6. Electrical connections

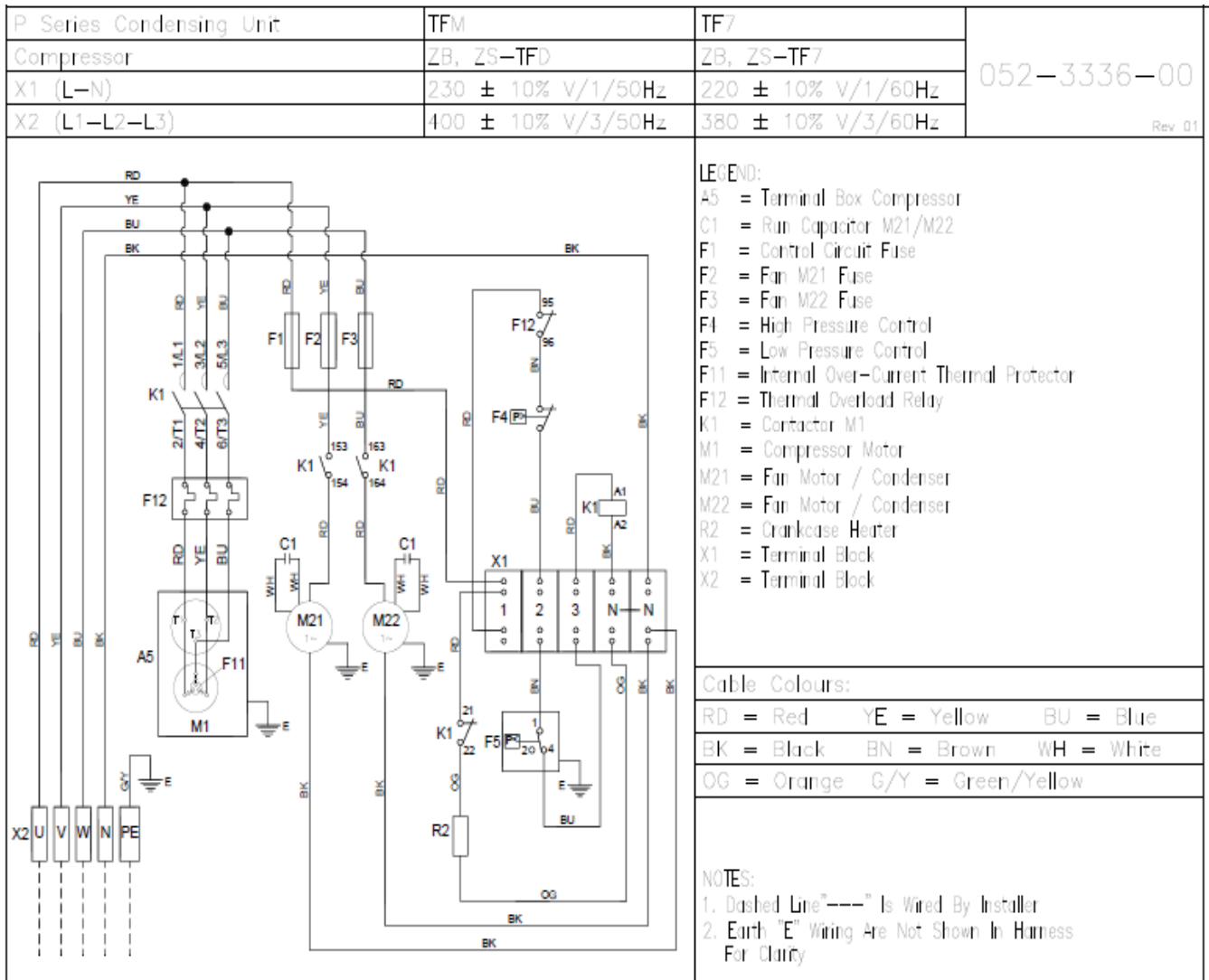

P Series Condensing Unit	TF5	052-3336-02
Compressor	ZB, ZS-TF5	
X1	220 ± 10% V/1/60Hz	
X2 (L1-L2-L3)	220 ± 10% V/3/60Hz	

Rev 01

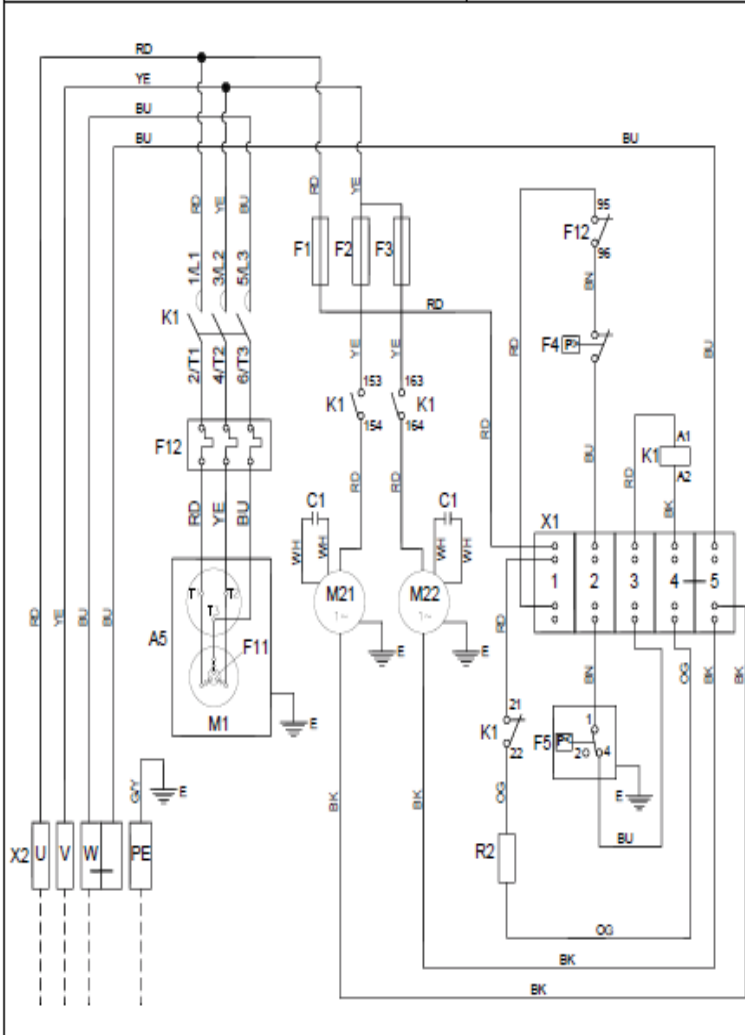

**LEGEND:**

- A5 = Terminal Box Compressor
- C1 = Run Capacitor M21/M22
- F1 = Control Circuit Fuse
- F2 = Fan M21 Fuse
- F3 = Fan M22 Fuse
- F4 = High Pressure Control
- F5 = Low Pressure Control
- F11 = Internal Over-Current Thermal Protector
- F12 = Thermal Overload Relay
- K1 = Contactor M1
- M1 = Compressor Motor
- M21 = Fan Motor / Condenser
- M22 = Fan Motor / Condenser
- R2 = Crankcase Heater
- X1 = Terminal Block
- X2 = Terminal Block

**Cable Colours:**

- RD = Red      YE = Yellow      BU = Blue
- BK = Black    BN = Brown    WH = White
- OG = Orange   G/Y = Green/Yellow

**NOTES:**

1. Dashed Line "----" Is Wired By Installer
2. Earth "E" Wiring Are Not Shown In Harness For Clarity

## 7. CDU performance/technical data

### Condensing unit: PMX1A-ZB21-TF7-1

Compressor: ZB21KQE-TF7

Refrigerant: R404A dew point

Power supply 380-420 V / 3~ / 60 Hz

		-20	-15	-10	-5	0	5
Capacity kW	27	4.96	5.96	7.08	8.30	9.64	11.09
	32	4.61	5.54	6.57	7.71	8.95	10.29
	38	4.17	5.01	5.94	6.97	8.10	9.31
	43	3.77	4.54	5.39	6.33	7.36	8.47
	46	3.52	4.24	5.05	5.93	6.90	7.96
	49		3.94	4.69	5.53	6.44	

		-20	-15	-10	-5	0	5
Total Power Input kW	27	2.49	2.57	2.65	2.73	2.82	2.91
	32	2.77	2.85	2.93	3.01	3.10	3.19
	38	3.15	3.22	3.31	3.39	3.48	3.58
	43	3.50	3.57	3.66	3.74	3.84	3.93
	46	3.73	3.80	3.89	3.97	4.06	4.16
	49		4.05	4.13	4.21	4.30	

		-20	-15	-10	-5	0	5
COP	27	1.99	2.32	2.67	3.04	3.42	3.81
	32	1.66	1.95	2.24	2.56	2.88	3.22
	38	1.32	1.55	1.80	2.05	2.32	2.60
	43	1.08	1.27	1.47	1.69	1.92	2.16
	46	0.94	1.12	1.30	1.49	1.70	1.91
	49		0.97	1.14	1.31	1.50	

		-20	-15	-10	-5	0	5
Compressor Current 380V, A	27	4.43	4.52	4.60	4.68	4.78	4.90
	32	4.75	4.85	4.95	5.05	5.16	5.29
	38	5.21	5.33	5.44	5.55	5.68	5.82
	43	5.66	5.79	5.91	6.04	6.18	6.33
	46	5.95	6.09	6.23	6.36	6.50	6.67
	49		6.42	6.56	6.70	6.86	

\*R404A, evaporating -10°C, ambient 46°C, suction gas return 20°C, subcooling 0K

## Condensing unit: PMX2A-ZB45-TF7-1

Compressor: ZB45KQE-TF7

Refrigerant: R404A dew point

Power supply 380-420 V / 3~ / 60 Hz

		-20	-15	-10	-5	0	5
Capacity kW	27	9.83	11.81	14.01	16.44	19.08	21.94
	32	9.13	10.97	13.02	15.27	17.72	20.37
	38	8.25	9.92	11.77	13.80	16.03	18.43
	43	7.47	8.99	10.68	12.54	14.57	16.77
	46	6.97	8.41	10.00	11.75	13.67	15.75
	49		7.81	9.30	10.95	12.75	

		-20	-15	-10	-5	0	5
Total Power Input kW	27	4.80	4.95	5.10	5.26	5.43	5.60
	32	5.33	5.48	5.64	5.80	5.97	6.15
	38	6.05	6.20	6.36	6.53	6.70	6.88
	43	6.72	6.87	7.03	7.20	7.38	7.56
	46	7.16	7.31	7.47	7.64	7.81	7.99
	49		7.78	7.93	8.10	8.27	

		-20	-15	-10	-5	0	5
COP	27	2.05	2.39	2.75	3.12	3.52	3.92
	32	1.71	2.00	2.31	2.63	2.97	3.31
	38	1.36	1.60	1.85	2.12	2.39	2.68
	43	1.11	1.31	1.52	1.74	1.97	2.22
	46	0.97	1.15	1.34	1.54	1.75	1.97
	49		1.00	1.17	1.35	1.54	

		-20	-15	-10	-5	0	5
Compressor Current 380V, A	27	8.91	9.10	9.30	9.52	9.74	9.96
	32	9.58	9.78	10.00	10.22	10.46	10.70
	38	10.53	10.74	10.97	11.21	11.46	11.71
	43	11.46	11.68	11.91	12.16	12.42	12.68
	46	12.08	12.30	12.54	12.79	13.04	13.31
	49		12.97	13.21	13.46	13.72	

\*R404A, evaporating -10°C, ambient 46°C, suction gas return 20°C, subcooling 0K

## Condensing unit: PMX1A-ZB21-TF5-1

Compressor: ZB21KQE-TF5

Refrigerant: R404A dew point

Power supply 220-230 V / 3~ / 60 Hz

Capacity kW		-20	-15	-10	-5	0	5
	27	4.96	5.96	7.08	8.30	9.64	11.09
32	4.61	5.54	6.57	7.71	8.95	10.29	
38	4.17	5.01	5.94	6.97	8.10	9.31	
43	3.77	4.54	5.39	6.33	7.36	8.47	
46	3.52	4.24	5.05	5.93	6.90	7.96	
49		3.94	4.69	5.53	6.44		

Total Power Input kW		-20	-15	-10	-5	0	5
	27	2.49	2.57	2.65	2.73	2.82	2.91
32	2.77	2.85	2.93	3.01	3.10	3.19	
38	3.15	3.22	3.31	3.39	3.48	3.58	
43	3.50	3.57	3.66	3.74	3.84	3.93	
46	3.73	3.80	3.89	3.97	4.06	4.16	
49		4.05	4.13	4.21	4.30		

COP		-20	-15	-10	-5	0	5
	27	1.99	2.32	2.67	3.04	3.42	3.81
32	1.66	1.95	2.24	2.56	2.88	3.22	
38	1.32	1.55	1.80	2.05	2.32	2.60	
43	1.08	1.27	1.47	1.69	1.92	2.16	
46	0.94	1.12	1.30	1.49	1.70	1.91	
49		0.97	1.14	1.31	1.50		

Compressor Current 220V, A		-20	-15	-10	-5	0	5
	27	7.74	7.90	8.08	8.27	8.46	8.65
32	8.33	8.50	8.68	8.88	9.08	9.29	
38	9.16	9.34	9.53	9.74	9.95	10.17	
43	9.97	10.15	10.35	10.56	10.79	11.01	
46	10.51	10.69	10.90	11.11	11.33	11.56	
49		11.28	11.48	11.70	11.92		

\*R404A, evaporating -10°C, ambient 46°C, suction gas return 20°C, subcooling 0K

## Condensing unit: PMX2A-ZB45-TF5-1

Compressor: ZB45KQE-TF5

Refrigerant: R404A dew point

Power supply 220-230 V / 3~ / 60 Hz

		-20	-15	-10	-5	0	5
Capacity kW	27	9.83	11.81	14.01	16.44	19.08	21.94
	32	9.13	10.97	13.02	15.27	17.72	20.37
	38	8.25	9.92	11.77	13.80	16.03	18.43
	43	7.47	8.99	10.68	12.54	14.57	16.77
	46	6.97	8.41	10.00	11.75	13.67	15.75
	49		7.81	9.30	10.95	12.75	

		-20	-15	-10	-5	0	5
Total Power Input kW	27	4.80	4.95	5.10	5.26	5.43	5.60
	32	5.33	5.48	5.64	5.80	5.97	6.15
	38	6.05	6.20	6.36	6.53	6.70	6.88
	43	6.72	6.87	7.03	7.20	7.38	7.56
	46	7.16	7.31	7.47	7.64	7.81	7.99
	49		7.78	7.93	8.10	8.27	

		-20	-15	-10	-5	0	5
COP	27	2.05	2.39	2.75	3.12	3.52	3.92
	32	1.71	2.00	2.31	2.63	2.97	3.31
	38	1.36	1.60	1.85	2.12	2.39	2.68
	43	1.11	1.31	1.52	1.74	1.97	2.22
	46	0.97	1.15	1.34	1.54	1.75	1.97
	49		1.00	1.17	1.35	1.54	

		-20	-15	-10	-5	0	5
Compressor Current 220V, A	27	14.72	15.03	15.37	15.72	16.09	16.46
	32	15.83	16.16	16.52	16.89	17.28	17.68
	38	17.40	17.75	18.13	18.52	18.93	19.35
	43	18.93	19.29	19.68	20.09	20.51	20.95
	46	19.96	20.32	20.71	21.12	21.55	21.99
	49		21.42	21.82	22.24	22.67	

\*R404A, evaporating -10°C, ambient 46°C, suction gas return 20°C, subcooling 0K

## Condensing unit: PMX1A-ZB26-TFM-1

Compressor: ZB26KQE-TFD

Refrigerant: R404A dew point

Power supply 380-420 V / 3~ / 60 Hz

Capacity kW		-20	-15	-10	-5	0	5
	27	4.66	5.60	6.64	7.79	9.05	10.41
32	4.32	5.19	6.15	7.21	8.37	9.63	
38	3.89	4.67	5.53	6.48	7.52	8.65	
43	3.50	4.21	4.98	5.84	6.78	7.80	
48		3.72	4.41	5.17			

Total Power Input kW		-20	-15	-10	-5	0	5
	27	2.46	2.53	2.60	2.68	2.76	2.85
32	2.75	2.82	2.89	2.97	3.06	3.15	
38	3.14	3.22	3.29	3.37	3.46	3.54	
43	3.52	3.59	3.67	3.75	3.83	3.92	
48		4.02	4.09	4.17			

COP		-20	-15	-10	-5	0	5
	27	1.89	2.21	2.55	2.91	3.27	3.65
32	1.57	1.84	2.13	2.43	2.74	3.06	
38	1.24	1.45	1.68	1.92	2.18	2.44	
43	0.99	1.17	1.36	1.56	1.77	1.99	
48		0.93	1.08	1.24			

Compressor Current 400V, A		-20	-15	-10	-5	0	5
	27	5.09	5.18	5.28	5.38	5.49	5.61
32	5.45	5.55	5.65	5.76	5.87	6.00	
38	5.97	6.08	6.19	6.30	6.42	6.54	
43	6.49	6.60	6.71	6.83	6.95	7.07	
48		7.21	7.32	7.44			

\*R404A, evaporating -10°C, ambient 46°C, suction gas return 20°C, subcooling 0K

## Condensing unit: PMX2A-ZB38-TFM-1

Compressor: ZB38KQE-TFD

Refrigerant: R404A dew point

Power supply 380-420 V / 3~ / 60 Hz

Capacity kW		-20	-15	-10	-5	0	5
	27	6.88	8.28	9.83	11.56	13.44	15.49
32	6.39	7.68	9.12	10.71	12.45	14.35	
38	5.76	6.92	8.21	9.64	11.21	12.92	
43	5.20	6.25	7.42	8.71	10.13	11.68	
48		5.55	6.59	7.74	9.01		

Total Power Input kW		-20	-15	-10	-5	0	5
	27	3.56	3.65	3.74	3.85	3.96	4.07
32	3.96	4.05	4.15	4.26	4.37	4.49	
38	4.52	4.62	4.72	4.82	4.93	5.05	
43	5.05	5.15	5.25	5.35	5.46	5.57	
48		5.74	5.84	5.95	6.05		

COP		-20	-15	-10	-5	0	5
	27	1.94	2.27	2.63	3.00	3.40	3.80
32	1.61	1.89	2.20	2.51	2.85	3.20	
38	1.27	1.50	1.74	2.00	2.27	2.56	
43	1.03	1.21	1.41	1.63	1.85	2.10	
48		0.97	1.13	1.30	1.49		

Compressor Current 400V, A		-20	-15	-10	-5	0	5
	27	5.88	5.97	6.07	6.18	6.30	6.43
32	6.28	6.39	6.50	6.62	6.74	6.87	
38	6.87	6.99	7.11	7.23	7.36	7.49	
43	7.46	7.58	7.71	7.83	7.96	8.09	
48		8.28	8.40	8.53	8.65		

\*R404A, evaporating -10°C, ambient 46°C, suction gas return 20°C, subcooling 0K



## Condensing unit: PMX2A-ZB38-TFM-1

Compressor: ZB38KQE-TFD

Refrigerant: R134a

Power supply 380-420 V / 3~ / 60 Hz

		-20	-15	-10	-5	0	5
Capacity kW	27		4.45	5.62	6.97	8.52	10.28
	32		4.19	5.32	6.61	8.09	9.77
	38		3.89	4.96	6.17	7.57	9.15
	43		3.63	4.64	5.80	7.12	8.62
	48			4.32	5.41	6.66	8.08

		-20	-15	-10	-5	0	5
Total Power Input kW	27		2.03	2.09	2.16	2.23	2.31
	32		2.22	2.29	2.36	2.44	2.53
	38		2.49	2.57	2.64	2.72	2.82
	43		2.75	2.83	2.90	2.99	3.08
	48			3.12	3.20	3.29	3.39

		-20	-15	-10	-5	0	5
COP	27		2.19	2.69	3.23	3.82	4.45
	32		1.89	2.32	2.80	3.32	3.87
	38		1.56	1.93	2.34	2.78	3.25
	43		1.32	1.64	2.00	2.38	2.80
	48			1.39	1.69	2.03	2.38

		-20	-15	-10	-5	0	5
Compressor Current 400V, A	27		5.11	5.15	5.18	5.22	5.26
	32		5.19	5.26	5.32	5.38	5.45
	38		5.38	5.49	5.58	5.67	5.76
	43		5.62	5.76	5.87	5.98	6.10
	48			6.10	6.23	6.36	6.50

\*R134a, evaporating -10°C, ambient 46°C, suction gas return 20°C, subcooling 0K

## Condensing unit: PMX2A-ZB48-TFM-1

Compressor: ZB48KQE-TFM

Refrigerant: R404A dew point

Power supply 380-420 V / 3~ / 50 Hz

Capacity kW		-20	-15	-10	-5	0	5
	27	8.93	10.75	12.79	15.05	17.53	20.23
32	8.30	9.99	11.87	13.96	16.26	18.76	
38	7.49	9.02	10.72	12.59	14.66	16.92	
43	6.78	8.16	9.70	11.40	13.27	15.33	
48	6.02	7.26	8.63	10.15	11.84	13.68	

Total Power Input kW		-20	-15	-10	-5	0	5
	27	4.32	4.42	4.54	4.66	4.79	4.92
32	4.82	4.93	5.04	5.16	5.29	5.43	
38	5.50	5.61	5.73	5.86	5.98	6.12	
43	6.15	6.27	6.38	6.51	6.63	6.76	
48	6.88	7.00	7.11	7.23	7.35	7.47	

COP		-20	-15	-10	-5	0	5
	27	2.07	2.43	2.82	3.23	3.66	4.11
32	1.72	2.03	2.35	2.70	3.07	3.45	
38	1.36	1.61	1.87	2.15	2.45	2.77	
43	1.10	1.30	1.52	1.75	2.00	2.27	
48	0.87	1.04	1.21	1.40	1.61	1.83	

Compressor Current 400V, A		-20	-15	-10	-5	0	5
	27	8.17	8.29	8.43	8.57	8.72	8.88
32	8.73	8.86	9.01	9.16	9.32	9.49	
38	9.54	9.69	9.84	10.00	10.17	10.34	
43	10.34	10.50	10.66	10.83	10.99	11.17	
48	11.29	11.45	11.62	11.78	11.94	12.11	

\*R404A, evaporating -10°C, ambient 46°C, suction gas return 20°C, subcooling 0K

Family			PMX	
Nominal HP Rating			3	6
Model Name			PMX1A-ZB21-TF7-1	PMX2A-ZB45-TF7-1
Performance	R404a ET/AT/RGT	°C	-6/49/20 C	
	Capacity	kW	5.35	10.61
	COP	W/W	1.28	1.32
	Sound Pressure Level @ 1m	dB(A)	56	60
Compressor	Model		ZB21KQE-TF7-558	ZB45KQE-TF7-558
	MCC	A	10.3	17.7
	LRA	A	39	70
	Oil Type		POE	
	Oil Recharge Volume	l	1.33	1.66
Fan motor	Number of fan		1	2
	Blade Diameter	mm	450	450
	Fan Speed	rpm	933	933
	Air Flow	m <sup>3</sup> /hr	3483	6966
	Total Current	A	0.75	1.5
	Total Power Input	W	145	290
	Capacitor	µF/V	3 / 450	3 / 450
	Receiver	R404a	kg	4.4
Electrical	Mains Supply Voltage	V	380V ± 10%, 3PH + Neutral	380V ± 10%, 3PH + Neutral
	Mains Supply Frequency	Hz	60	60
	Unit MOC	A	9.6	16.6
Accessories	Electrical enclosure with			
	Compressor Contactor	A	12	18
	Auxiliary Contact Block		2 x NO	2 x NO
	Thermal Overload Relay Range	A	7-10	12-18
	Compressor Crankcase Heater	W	40	40
	Suction Isolation Valve	inch	3/4	7/8
	Liquid Isolation Valve	inch	1/2	1/2
	Non Adjustable HP Switch		31 Bar Cut Out/ 24 Bar Cut In	
	Adjustable LP Switch		Cut Out > 2 bar	
	Liquid Line Filter Drier		EK Series	
Liquid Line Sight Glass		HMI Series		
Dimension	W X D X H	mm	1029 X 424 X 840	1029 X 424 X 1242
Weight	Net	kg	79	108
	Gross	kg	117	152

Family			PMX	
Nominal HP Rating			3	6
Model Name			PMX1A-ZB21-TF5-1	PMX2A-ZB45-TF5-1
Performance	R404a ET/AT/RGT	°C	-6/49/20 C	
	Capacity	kW	5.35	10.61
	COP	W/W	1.28	1.32
	Sound Pressure Level @ 1m	dB(A)	56	60
Compressor	Model		ZB21KQE-TF5-558	ZB45KQE-TF5-558
	MCC	A	17.0	32.4
	LRA	A	77	156
	Oil Type		POE	
	Oil Recharge Volume	l	1.33	1.66
Fan motor	Number of fan		1	2
	Blade Diameter	mm	450	450
	Fan Speed	rpm	933	933
	Air Flow	m <sup>3</sup> /hr	3483	6966
	Total Current	A	0.75	1.5
	Total Power Input	W	145	290
	Capacitor	µF/V	3 / 450	3 / 450
	Receiver	R404a	kg	4.4
Electrical	Mains Supply Voltage	V	220V ± 10%, 3PH	220V ± 10%, 3PH
	Mains Supply Frequency	Hz	60	60
	Unit MOC	A	15.1	28.0
Accessories	Electrical enclosure with			
	Compressor Contactor	A	18	38
	Auxiliary Contact Block		2 x NO	2 x NO
	Thermal Overload Relay Range	A	12-18	23-32
	Compressor Crankcase Heater	W	40	40
	Suction Isolation Valve	inch	3/4	7/8
	Liquid Isolation Valve	inch	1/2	1/2
	Non Adjustable HP Switch		31 Bar Cut Out/ 24 Bar Cut In	
	Adjustable LP Switch		Cut Out > 2 bar	
	Liquid Line Filter Drier		EK Series	
Liquid Line Sight Glass		HMI Series		
Dimension	W X D X H	mm	1029 X 424 X 840	1029 X 424 X 1242
Weight	Net	kg	79	108
	Gross	kg	117	152

Family			PMX	
Nominal HP Rating			3.5	5
Model Name			PMX1A-ZB26-TFM-1	PMX2A-ZB38-TFM-1
Performance	R404a ET/AT/RGT	°C	-6/48/20 C	
	Capacity	kW	5.02	7.5
	COP	W/W	1.21	1.27
	Sound Pressure Level @ 1m	dB(A)	56	60
Compressor	Model		ZB26KQE-TFD-558	ZB38KQE-TFD-558
	MCC	A	9	13.5
	LRA	A	46	63
	Oil Type		POE	
	Oil Recharge Volume	l	1.36	1.95
Fan motor	Number of fan		1	2
	Blade Diameter	mm	450	450
	Fan Speed	rpm	830	830
	Air Flow	m <sup>3</sup> /hr	2916	5904
	Total Current	A	0.87	1.74
	Total Power Input	W	116	246
	Capacitor	µF/V	3 / 450	3 / 450
	Receiver	R404a	kg	4.4
Electrical	Mains Supply Voltage	V	400V ± 10%, 3PH + Neutral	400V ± 10%, 3PH + Neutral
	Mains Supply Frequency	Hz	50	50
	Unit MOC	A	9.8	14.5
Accessories	Electrical enclosure with			
	Compressor Contactor	A	12	18
	Auxiliary Contact Block		2 x NO	2 x NO
	Thermal Overload Relay Range	A	7-10	12-18
	Compressor Crankcase Heater	W	40	40
	Suction Isolation Valve	inch	3/4	7/8
	Liquid Isolation Valve	inch	1/2	1/2
	Non Adjustable HP Switch		31 Bar Cut Out/ 24 Bar Cut In	
	Adjustable LP Switch		Cut Out > 2 bar	
	Liquid Line Filter Drier		EK Series	
Liquid Line Sight Glass		HMI Series		
Dimension	W X D X H	mm	1029 X 424 X 840	1029 X 424 X 1242
Weight	Net	kg	79	108
	Gross	kg	117	152

Family			PMX	
Nominal HP Rating				6.5
Model Name				PMX2A-ZB48-TFM-1
Performance	R404a ET/AT/RGT	°C	-6/48/20 C	
	Capacity	kW		9.84
	COP	W/W		1.36
	Sound Pressure Level @ 1m	dB(A)		60
Compressor	Model		ZB38KQE-TFD-558	
	MCC	A		19.1
	LRA	A		101
	Oil Type		POE	
	Oil Recharge Volume	l		1.66
Fan motor	Number of fan			2
	Blade Diameter	mm		450
	Fan Speed	rpm		830
	Air Flow	m <sup>3</sup> /hr		5904
	Total Current	A		1.74
	Total Power Input	W		246
	Capacitor	µF/V		3 / 450
Receiver	R404a	kg		6.3
Electrical	Mains Supply Voltage	V		400V ± 10%, 3PH + Neutral
	Mains Supply Frequency	Hz		50
	Unit MOC	A		15.74
Accessories	Electrical enclosure with			
	Compressor Contactor	A		18
	Auxiliary Contact Block			2 x NO
	Thermal Overload Relay Range	A		12-18
	Compressor Crankcase Heater	W		40
	Suction Isolation Valve	inch		7/8
	Liquid Isolation Valve	inch		1/2
	Non Adjustable HP Switch		31 Bar Cut Out/ 24 Bar Cut In	
	Adjustable LP Switch		Cut Out > 2 bar	
	Liquid Line Filter Drier		EK Series	
Liquid Line Sight Glass		HMI Series		
Dimension	W X D X H	mm		1029 X 424 X 1242
Weight	Net	kg		112
	Gross	kg		156

## ***8. Installation, system processing and commissioning***

Utmost care must be taken while handling the PMX condensing unit. Please go through the contents below to ensure proper handling.

### ***a. Inspection***

Inspect the condensing unit and any accessories shipped with them for damages or shortages before and during unloading. All items on bill of lading should be accounted for prior to signing the shipping receipt. Note any shortages or damage on delivery receipt (specify the extent and type of damage found). Unit should be inspected carefully for concealed damage. Notify Copeland sales/application personnel of the damage immediately. Request an immediate joint inspection and do not repair the unit until inspected by Copeland's representative.

The system is shipped with a holding charge of dry nitrogen. Check to see that pressure is still in the unit upon receipt. Report lack of pressure immediately to the Copeland's application/sales representative.

### ***b. Location and fixing***

The unit should always be installed in a location that ensures clean air flow. It is recommended that a clearance of 300 mm from the wall (or the next unit) be maintained from the unit's left and rear panels whereas a clearance of 500 mm must be maintained from the unit's right, top and front panels (seen facing the front of the unit). Both service access and airflow have been considered in making these recommendations. Where multiple units are to be installed in the same location, the contractor needs to consider each individual case carefully. There can be many variations of unit quantities and available space and it is not the intention of this manual to go over these. Ideally, the unit should be mounted on a solid concrete slab with anti-vibration pads between unit feet and concrete. However, the PMX condensing unit has also been designed for wall mounting on suitable brackets. Wall mounting brackets are not included. Another factor to consider in finding a good installation site is the direction of the prevailing wind. For example if the air leaving the condenser faces the prevailing wind, the air flow through the condenser can be impeded, causing high condensing temperatures ultimately resulting in reducing unit life. A baffle is a remedy for this situation.

### Fixing dimensions and distances - single fan unit

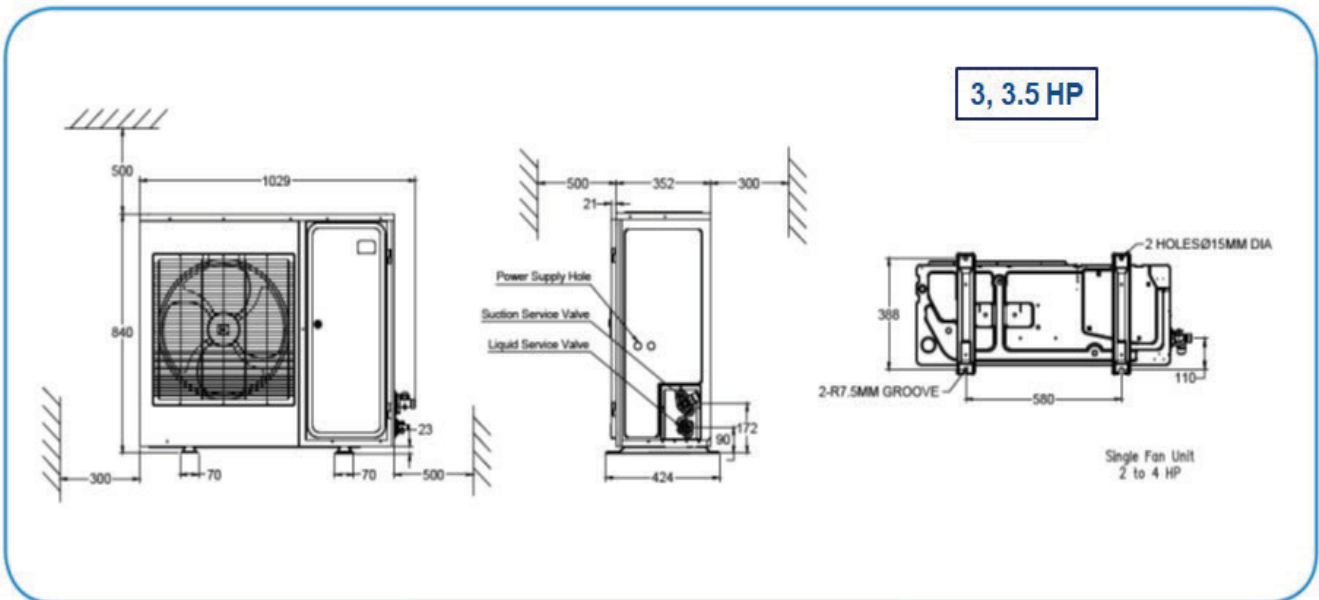

### Fixing dimensions and distances - dual fan unit

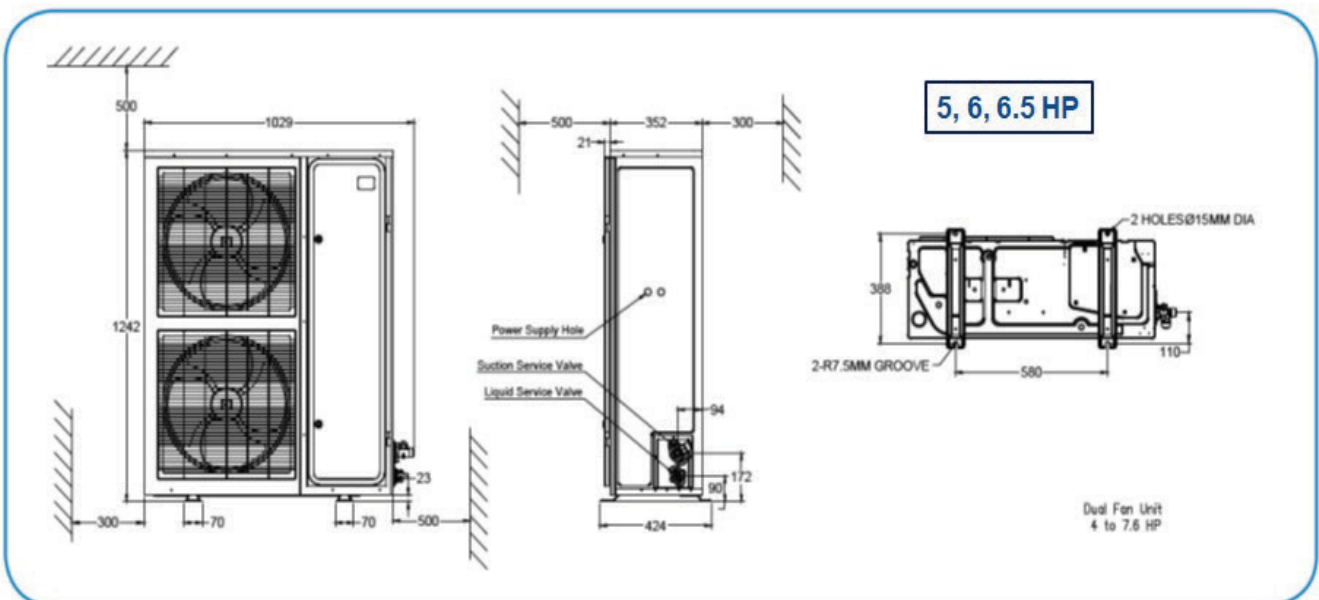

### c. Refrigeration piping installation

All interconnecting pipes should be of refrigeration grade, clean, dehydrated and must remain capped at both ends until installation. Even during installation, if the system is left for any reasonable period (say two hours), pipes should be re-capped to prevent moisture and contaminants from entering the system.

Do not assume that the service connection sizes on the unit (at the service valves) are the correct size to run your interconnecting refrigeration pipes. The service valve sizes have been selected for convenience of installation and in some cases (larger units) these may be considered too small. However, for the very short pipe run within our units, these service connection sizes are adequate.



The pipe should be sized to ensure optimum performance and proper oil return. The sizing must also consider the full capacity range through which this particular unit will need to operate.

Pipe runs should be kept as short as possible, using the minimum number of directional changes. Use large radius bends and avoid trapping of oil and refrigerant. This is particularly important for the suction line. The suction line should ideally slope gently towards the unit. Recommendation slope is 1/200~1/250. P traps, double risers and reduced pipe diameters may be required for suction lines where long vertical risers cannot be avoided. All pipes should be adequately supported to prevent sagging which can create oil traps.

The recommended pipe clamp support distance is shown in the table.

Tube Size	Max distance between 2 clamp support
1/2 inch	1.2 M
5/8 inch	1.5 M
7/8 inch	1.85 M
1 1/8 inch	1.2 M

#### ***d. Refrigerant line insulation***

- Insulate suction lines from the evaporators to the condensing unit with minimum 1" thickness closed-cell type insulation on low temperature circuits.
- Long liquid lines run in areas exposed to high temperatures should be fully insulated with minimum 1/2" insulation.
- Suction and liquid lines should never be taped or soldered together.

#### ***e. Electrical***

- a. All electrical work must be done in accordance with the National Electrical Code and existing local codes.
- b. Power supply must be the same as specified on the unit name plate.
- c. Voltage fluctuations in excess of 10 percent must be corrected.
- d. Before starting the unit, ensure that all protective devices are in place and that all wiring is secure.

#### ***f. Brazing recommendation***

Maintain a flow of oxygen-free nitrogen through the system at a very low pressure during brazing. Nitrogen displaces the air and prevents the formation of copper oxides in the system. If copper oxidization is allowed to form, the copper oxide material can later be swept through the system and block screens such as those protecting capillary tubes, thermal expansion valves, and accumulator oil return holes. This minimizes any entry of contaminants and moisture.

- Remove the liquid line connection cap.
- Then remove the suction connection cap.
- Open both valves midway.
- Care should be taken to avoid the holding charge from releasing too quickly.
- Be sure tube fitting inner diameter and tube outer diameter are clean prior to assembly.
- Since both tubes are extended from the condensing unit housing, we recommend insulating the housing by using a wet cloth on the copper tubing.
- Recommended brazing materials: a copper / phosphorous or copper / phosphorous / silver alloy rod should be used for joining copper to copper whereas to join dissimilar or ferric metals, use a silver alloy rod, either flux coated or with a separate.
- Use a double tip torch.

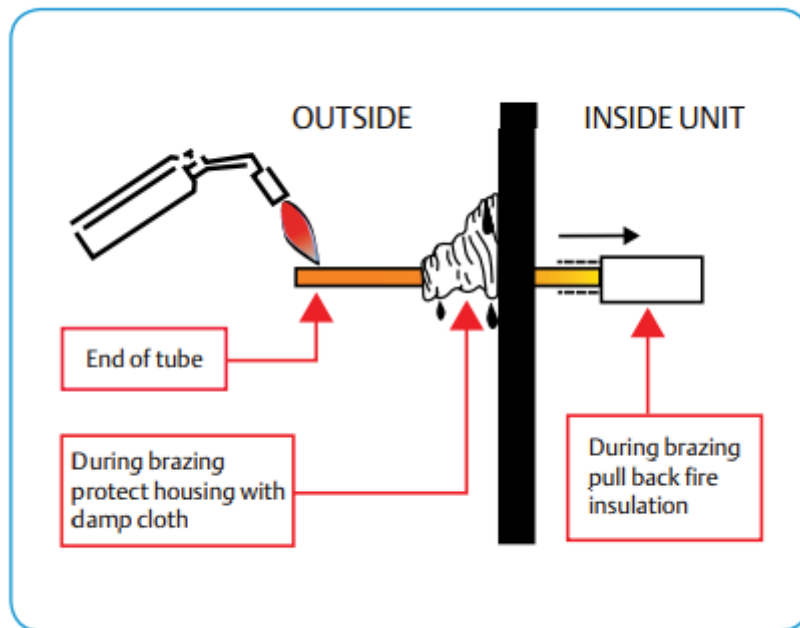

## **g. Start-up & operation**

### **Initial pressure test (by vacuum and nitrogen)**

#### **Step-by-step**

- Use a 4-port gauge manifold with 3/8" hose and connections to the vacuum pump. The vacuum gauge does not have to be connected for this part of the process.
- Connect the gauges to service ports provided on receiver valve and suction tube. In order to remove any non-condensable that may have entered the system during installation, follow these steps:
- Start the vacuum pump. The evaporator fan should be running and the compressor crankcase heater is energized at this point. This will involve powering up the unit so it is important to disconnect the live feed wire to the compressor contactor (so the compressor cannot run and the crankcase heater can be energized).
- Open both valves on the manifold and then open the main vacuum valve on the pump. Run the system until the vacuum level of -0.85 bar (as read on manifold gauge) is achieved.

- Shut off the main vacuum pump valve. Check for vacuum rise using the manifold compound gauge. A rise would indicate a large leak.
- If vacuum holds for 10 minutes, break vacuum with nitrogen and pressurize to 20 bar. Check for leaks and repair leakage.

## Leak check

The success of all the subsequent commissioning depends on a leak free system, free of contaminants, free of oxides, free of non-condensable's, that has been evacuated to a low vacuum and charged with the prescribed refrigerant.

Leak test is particularly important for field-connected systems. Typically, field systems lose as much as 20%-30% of their refrigeration charge annually. This is not only an unnecessary expense but also damages the environment. Compressor oil can be lost at the same time as refrigerant and eventually lead to compressor failure. (Time spent on leak test will eventually reduce the time spent on the evacuation process).

Ensure that all service valves are open during the leak test process. It is important to recheck all joints within the unit as well as the external joints.

- a. The unit is shipped with a holding charge of dry nitrogen and should be leak free.
- b. Ensure that the test pressure do not exceed the system design pressures.
- c. Do not expose system pressure control LP to test pressures below the design pressure. This can damage the pressure controls.
- d. Using an approved, calibrated electronic gas leak detector, leak test the entire system paying attention to all joints.
- e. Periodically check functionality of the electronic leak detector during this process.
- f. To further check system integrity, spray a soapy water solution over joins then visually inspect for bubbles.
- g. Leave the system under pressure for a designated period (24 Hours).
- h. Check and record the ambient temperatures and the system pressure with calibrated approved instruments. This process is to be carried out every 8-12 hours during the pressure testing process.
- i. If the test pressures cannot be maintained, repeat the leak testing process employing the isolation of sections of the system to determine the source of leaks. Repair the leak and repeat the leak testing process until system can be signed off as leak free and approved by authorized personnel.
- j. Record findings and confirm pressure testing process completion.

## Evacuation

- a. After the system is leak checked, connect approved dual stage vacuum pump sized to application with fresh oil to evacuation valve.
- b. Ensure all inline system shut-off valves and solenoid valves are fully open.
- c. Evacuate the system to 300 microns.
- d. A triple evacuation is recommended. The third and final evacuation should achieve a value of 300 microns or less. After this vacuum is reached, system is ready for refrigerant charging and add as much refrigerant as possible into the receiver.

## Charging and commissioning

### Reminder

- The scroll compressor design requires system charging with liquid refrigerant into the liquid line.
- Do not vapor charge the ZX scroll unit. After ensuring all valves are opened and system is vacuumed properly, only then start the refrigerant charging process.

### Step-by-step:

1. Ensure that there is no power supply to the ZX unit. The Liquid Line solenoid needs to be kept open for the charging process and this may require a temporary power feed to it.
2. Connect the refrigerant cylinder to main service hose and purge line at the manifold end.
3. Ensure correct orientation of the refrigerant cylinder. Follow cylinder labeling/instructions so that liquid refrigerant can be charged into the system. This will be charged through the high-pressure side of the manifold and ZX unit liquid service valve.
4. Now open the liquid service valve (off the back seat). With a good vacuum in the system, the refrigerant cylinder correct orientation and at ambient, you should not need to run the compressor at all.
5. The compressor can then be started, and the unit continued to be charged (with liquid refrigerant through the liquid service valve). The quantity of charge should always be measured. See note.
6. Turn off the unit and open the receiver outlet valve (which was almost fully closed earlier).
7. The system needs to be operated down to its design evaporating temperature before you can be sure the charge is correct. It is at this point that the normal refrigeration operational checks can be carried out - such as checking the liquid line sight glass for violent bubbles and the operating pressures.

In the event that the system is still short of refrigerant, repeat from step #5 onwards.

Refrigerant charging is regarded full/complete when the operating temperature of the system has been stable for some time and the liquid line sight glass is clear.

## ***h. Maintenance***

---

### **Condenser fins**

Condenser fins become dirty over time as ambient air is induced to the condenser. Dirty coil surfaces result in high condensing temperatures and poor unit performance. Regular cleaning is recommended with frequency depending on the installation and the surrounding environment. As a general guide, it is advisable to do this at least once every two months.

Fins should be cleaned with liquid detergent diluted with clean water. Before washing, a light brush downward (in the direction of the fins) should be done to remove heavy deposits.

### **Electrical connections**

Check tightness of electrical connections occasionally.

### **Routine leak test**

All joints should be checked for leaks during site visits. All joints should be leak tested once a year. Condenser fan(s) and motor(s), an annual inspection of these items is recommended. Fastenings may loosen, bearings may wear, and fans may require cleaning of solid deposits which can cause imbalance.



**TURN OFF OR DISCONNECT THE ELECTRICAL POWER SOURCE BEFORE CLEANING THE CONDENSER COIL OR DOING MAINTENANCE.**

# System start-up and operational check sheet

Client details	
Facility/Customer Name :	
Address :	
Contact Details :	
Installer :	
Installation Date :	

ZX condensing unit info.	
CDU Model :	
Serial Number :	
CDU Location :	
Indoor Unit Make/Model :	

System details	
Room/Case ID :	
Pipe Length (approx.) :	
OAT @ Start-Up/Check :	
PSI Leak Test :	<b>PSIG</b>
Duration :	<b>Hours</b>
System is Leak Tight :	<b>Y / N</b>
Triple Evacuation :	<b>Y / N</b>
Micron Gauge Reading :	<b>microns</b>
Total Evacuation :	<b>PSIG @ # of Hrs</b>
Refrigerant :	
Total Charge :	<b>Kg.</b>
Sight Glass Clear :	<b>Y / N</b>
Evap Fans Running :	<b>Y / N</b>
Liquid Line Insulation :	<b>Y / N</b>
Sound and Vibration	

System operation	
COMP Voltage :	<b>V</b>
COMP Current :	<b>A</b>
Suction Pressure :	<b>PSIG/Bar</b>
Liquid Line Pressure :	<b>PSIG/Bar</b>
COMP Suction Temp :	<b>°C</b>
COMP Disch Temp :	<b>°C</b>
Liquid Line Temp :	<b>°C</b>
Compressor SH :	<b>K</b>
Subcooling :	<b>K</b>
Adjustable LP Setpoint :	<b>PSIG</b>
Design/Operating Temp :	<b>°C</b>
Actual Room/Case Temp :	<b>°C</b>
Condenser Fins :	

Comments

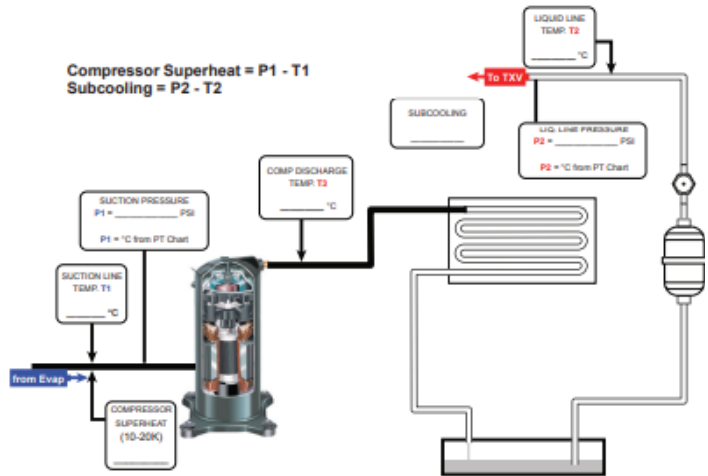

Prepared by: \_\_\_\_\_  
 Date: \_\_\_\_\_

Confirmed by: \_\_\_\_\_  
 Date: \_\_\_\_\_





## About Copeland

Copeland is a global leader in sustainable heating, cooling, refrigeration and industrial solutions. We help commercial, industrial, refrigeration and residential customers reduce their carbon emissions and improve energy efficiency. We address issues like climate change, growing populations, electricity demands and complex global supply chains with innovations that advance the energy transition, accelerate the adoption of climate friendly low GWP (Global Warming Potential) and natural refrigerants, and safeguard the world's most critical goods through an efficient and sustainable cold chain. We have over 18,000 employees, with feet on the ground in 50 countries - a global presence that makes it possible to serve customers wherever they are in the world and meet challenges with scale and speed. Our industry-leading brands and diversified portfolio deliver innovation and technology proven in over 200 million installations worldwide. Together, we create sustainable solutions that improve lives and protect the planet today and for future generations. For more information, visit [copeland.com](https://www.copeland.com).

Follow us:



**To learn more, visit [copeland.com](https://www.copeland.com)**

PMX condensing unit  
8648192 ©2024 Copeland LP.

**COPELAND**